

## 1. Voltage reduction capability of OS-CON

While there is a tendency to downsize switching power supplies capacitors still remain one of the parts occupying large areas of circuit boards. The working temperature is an important consideration when selecting a capacitor, since it generally results in widely varying capacitor characteristics. The following experiment shows the superior ripple removal capability of the OS-CON at higher frequencies in wide range of working temperature.

### 1-1. The number of capacitors needed to keep the same ripple voltage level

#### (a) Experiment content

A general chopper switching power supply was used to test the OS-CON against two alternatives. SANYO OS-CON, low-impedance aluminum electrolytic capacitor, and low-ESR tantalum capacitors were each connected as the capacitor in the output side smoothing circuit at working temperature range of -20°C, 25°C and 70°C to compare the output ripple voltage.

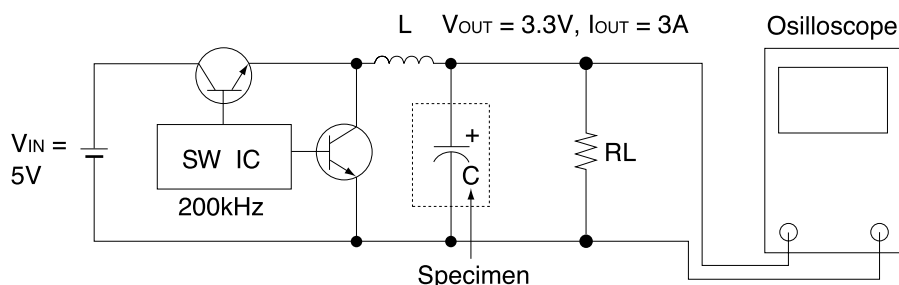

- (1) Initially SANYO OS-CON · 100uF/6.3V (6SVP100M ·  $\phi$  6.3mm × L6.0mm) was used as the output side smoothing capacitor (C) in the above test circuit, the ripple voltage was measured at ambient temperature of each temperature. Refer to table 3.
- (2) Low-impedance aluminum electrolytic capacitors and Low-ESR tantalum capacitors were selected for measurement at each temperature so that the ripple voltage became equal to that achieved when the OS-CON · 100uF/6.3V was used. Refer to table 3.
- (3) The ripple voltage was measured at each temperature (-20°C to 70°C) with an equal number of side smoothing capacitors to the 25°C conditions, and the rates of change in the ESR of the smoothing capacitors were calculated from the amounts of change. Refer to table 2.

#### (b) Experiment result

**Table1** On-board area ratios of capacitors at each temperature (when the ripple voltage is on the same level)

Ambient temperature	OS-CON	Aluminum Electrolytic capacitor	Tantalum capacitor
25°C	1	7.15	1.46
-20°C	1	16.7	1.46
70°C	1	4.77	1.46









**Table2** Rates of change in ESR on the basis of 25°C(※)

Ambient temperature	OS-CON	Aluminum Electrolytic capacitor	Tantalum capacitor
25°C	1	1	1
-20°C	1.14	3.03	1.27
70°C	0.952	0.587	0.85

$$\text{※Rate of change in ESR} = \frac{\text{Ripple voltage at ambient temperature} \times \text{Oscillation frequency at ambient temperature}}{\text{Ripple voltage at 25°C} \times \text{Oscillation frequency at 25°C}}$$

From the above results, it can be seen that SANYO OS-CON excels in temperature characteristics.

Table3 Measurement comparison at 25°C, -20°C and 70°C

Ambient temperature	25°C		
Capacitor type	OS-CON	Aluminum Electrolytic capacitor	Tantalum capacitor
capacitance/voltage	100μF/6.3V	680μF/6.3V	100μF/10V
ripple voltage	22.8mV	23.8mV	24.8mV
Size (※1) (mm)	6.6 X 6.6	10.5 X 10.5	7.5 X 4.5
On-board area ratio	1	7.15	1.46
Oscillation frequency	200kHz		
Fig	Fig1	Fig2	Fig3
Quantity			
Ambient temperature	-20°C		
Capacitor type	OS-CON	Aluminum Electrolytic capacitor	Tantalum capacitor
capacitance/voltage	100μF/6.3V	680μF/6.3V	100μF/10V
ripple voltage	20.8mV	24.4mV	25.2mV
Size (※1) (mm)	6.6 X 6.6	10.5 X 10.5	7.5 X 4.5
On-board area ratio	1	16.7	1.46
Oscillation frequency	250kHz		
Fig	Fig4	Fig5	Fig6
Quantity			
Ambient temperature	70°C		
Capacitor type	OS-CON	Aluminum Electrolytic capacitor	Tantalum capacitor
capacitance/voltage	100μF/6.3V	680μF/6.3V	100μF/10V
ripple voltage	25.6mV	24.0mV	24.8mV
Size (※1) (mm)	6.6 X 6.6	10.5 X 10.5	7.5 X 4.5
On-board area ratio	1	4.77	1.46
Oscillation frequency	170kHz		
Fig	Fig7	Fig8	Fig9
Quantity			

※1 The base plate dimensions were taken as the maximum dimensions except for Ta.

Table1 Comparison at 25°C

**OS-CON**  
**100 $\mu$ F/6.3V**

Fig 1 (1pc)

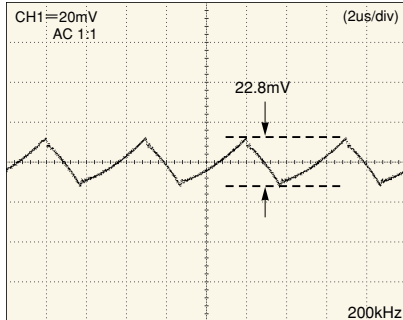

**aluminum electrolytic capacitor**  
**680 $\mu$ F/6.3V**

Fig 2 (3pc)

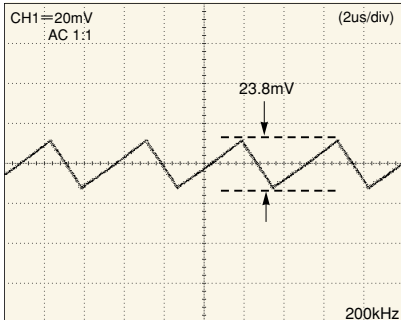

**Tantalum capacitor**  
**100 $\mu$ F/10V**

Fig 3 (2pc)

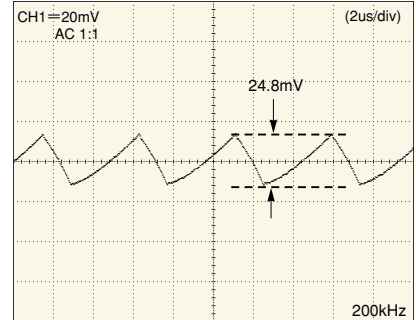
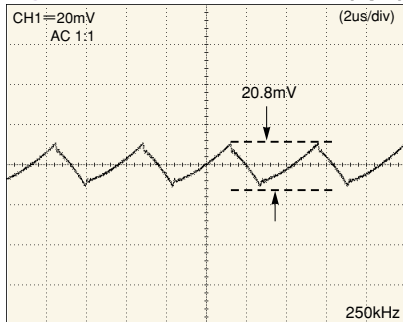

Table2 Comparison at -20°C

**OS-CON**  
**100 $\mu$ F/6.3V**

Fig 4 (1pc)



**aluminum electrolytic capacitor**  
**680 $\mu$ F/6.3V**

Fig 5 (7pc)

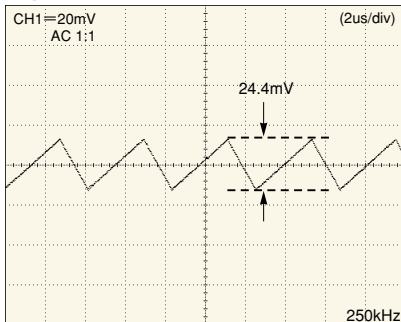

**Tantalum capacitor**  
**100 $\mu$ F/10V**

Fig 6 (2pc)

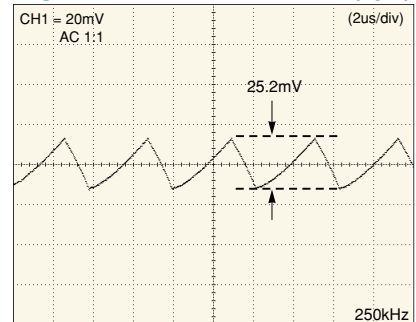
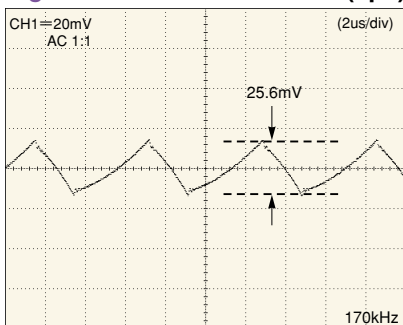

Table3 Comparison at 70°C

**OS-CON**  
**100 $\mu$ F/6.3V**

Fig 7 (1pc)



**aluminum electrolytic capacitor**  
**680 $\mu$ F/6.3V**

Fig 8 (2pc)

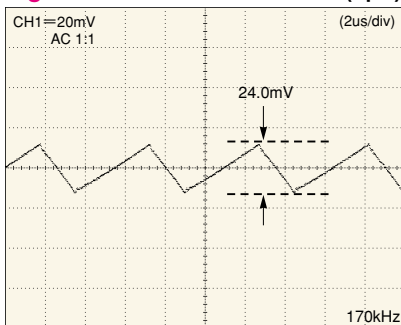

**Tantalum capacitor**  
**100 $\mu$ F/10V**

Fig 9 (2pc)

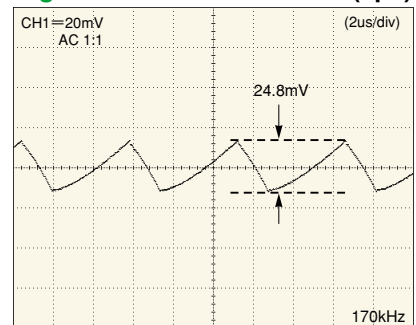

## 1-2. Ripple voltage removal capability before and after endurance test

### (a) Experiment content

**OS-CON** and low-impedance aluminum electrolytic capacitors were respectively connected to the output side of chopper switching power supply, as soothing capacitors. Output ripple voltage made by the two kinds of capacitor was respectively measured before and after endurance tests (125°C×1000h, rated voltage applied) of the capacitors.

The ripple voltage measurement was done at the ambient temperatures of 25°C, 0°C, and -20°C.

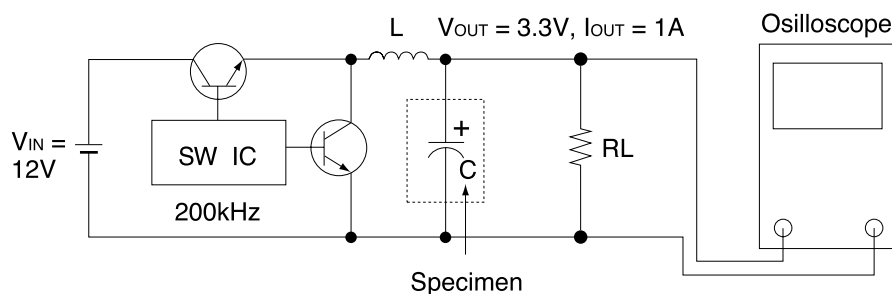

**OS-CON** 56  $\mu$  F/10V(10SVPD56M  $\phi$  6.3mm×L6mm) and low-impedance aluminum electrolytic capacitor 330  $\mu$  F /10V ( $\phi$  10mm×L10mm) were used for this experiment. Measured ESR value of the **OS-CON** was 38m $\Omega$ , while that of the aluminum electrolytic capacitor was 180m $\Omega$ . To match the equivalent ripple voltage one **OS-CON** brings, four pieces of the aluminum electrolytic capacitor were used.

$$\text{Output ripple voltage(outline)} = \frac{\text{Ripple current through coil}}{\text{ESR of capacitor}}$$

### (1) Specifications of test samples

	<b>OS-CON</b>	Aluminum electrolytic capacitor
capacitance/voltage	56 $\mu$ F/10V	330 $\mu$ F/10V
ESR	45m $\Omega$	300m $\Omega$
Category temperature range	-55°C ~ +125°C	-40°C ~ +125°C
Endurance	125°C × 2,000h	125°C × 2,000h
Size(mm)	 $\phi$ 6.3×L6	 $\phi$ 10×L10

### (2) ESR change of test samples

Ambient temperature in measuring	<b>OS-CON</b>		Aluminum electrolytic capacitor	
	Initial value	Value after 125°C×10V applied×1,000h	Initial value	Value after 125°C×10V applied×1,000h
25°C	38m $\Omega$	40m $\Omega$	180m $\Omega$	231m $\Omega$
0 °C	39m $\Omega$	41m $\Omega$	369m $\Omega$	663m $\Omega$
-20°C	38m $\Omega$	40m $\Omega$	907m $\Omega$	2,212m $\Omega$

(3) Endurance (125°C × 10V applied)

[ESR]

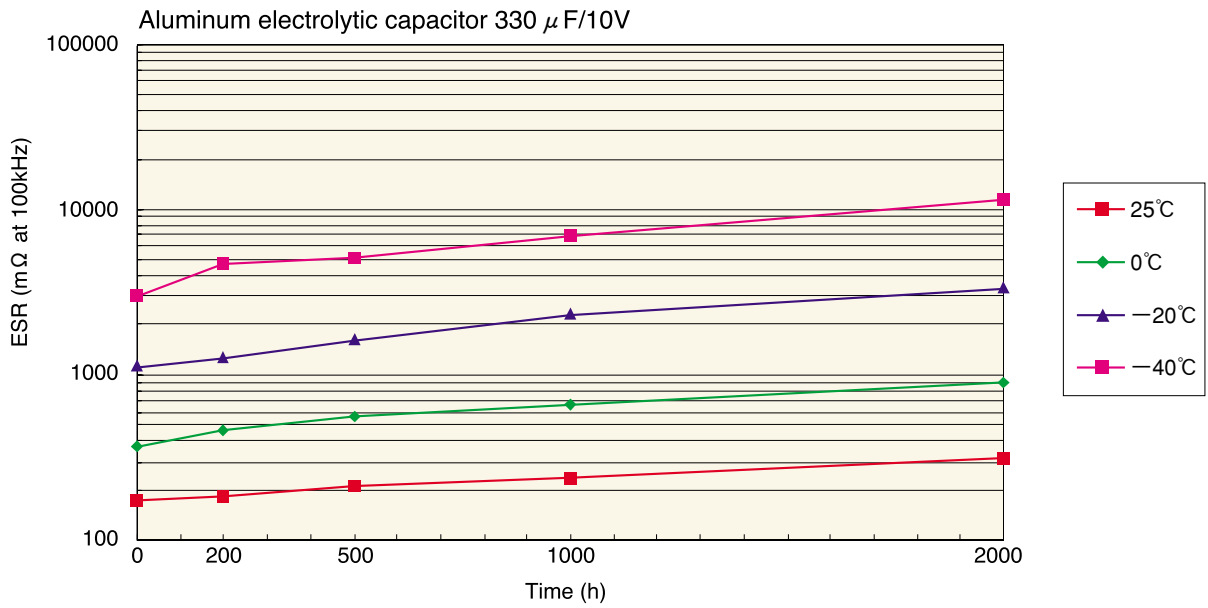
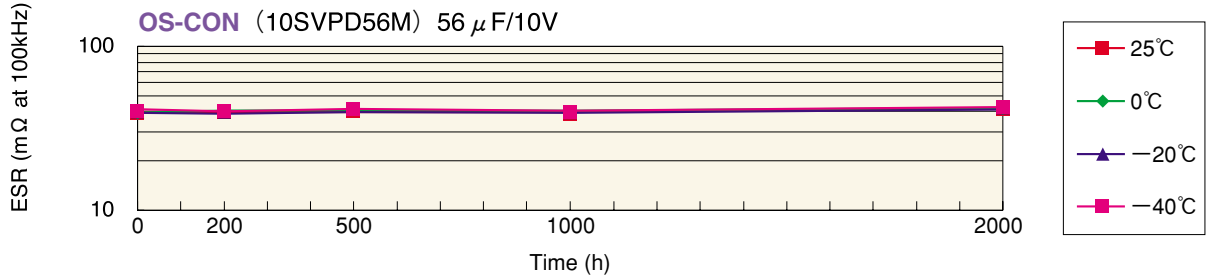

[Capacitance]

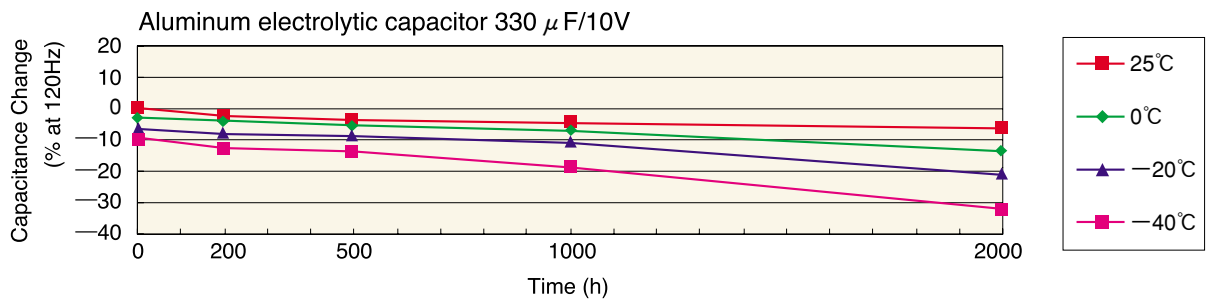
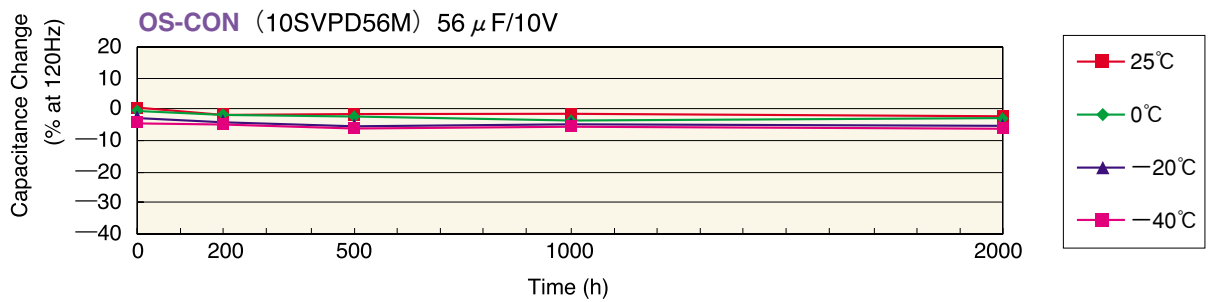

(b) Experiment result

(1) Initial ripple voltage waveform

**OS-CON (10SVPD56M)**  
56  $\mu$ F/10V

**Aluminum electrolytic capacitor**  
330  $\mu$ F/10V

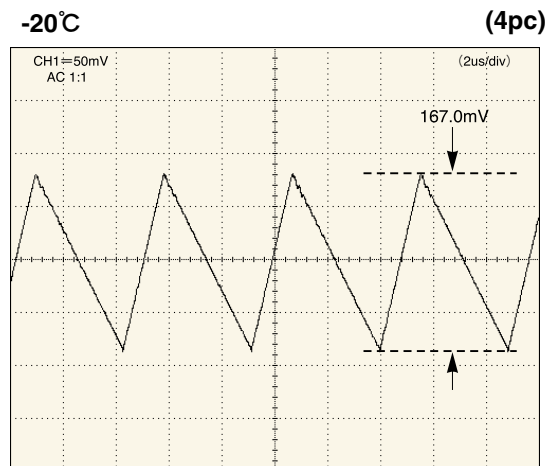
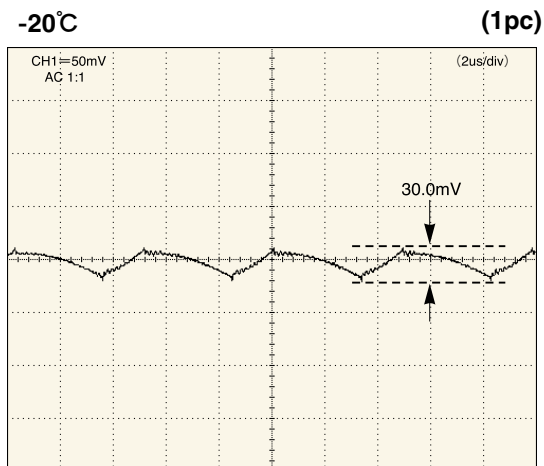
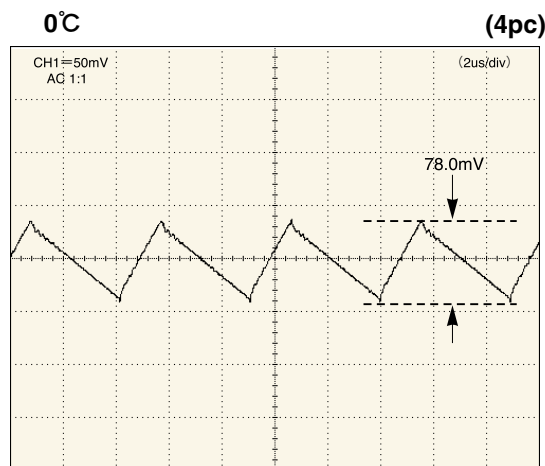
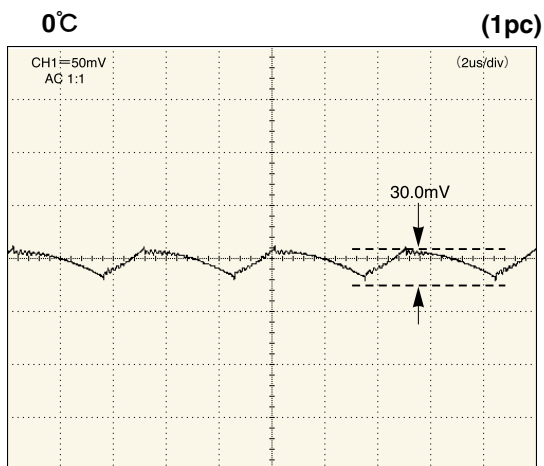
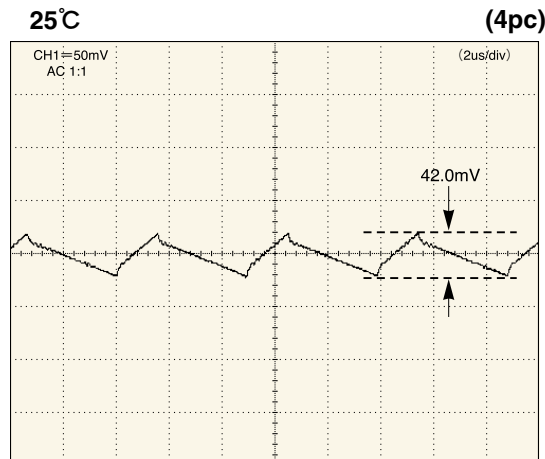
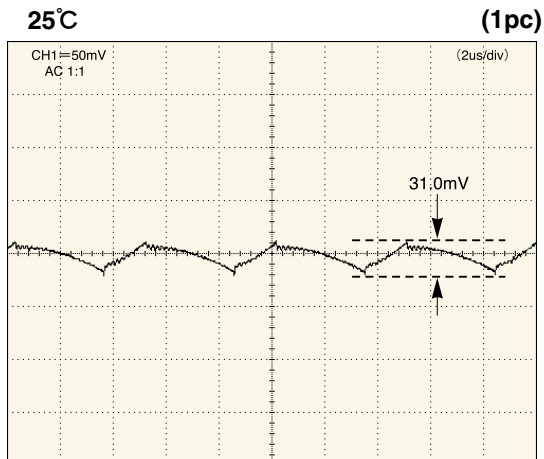

(2) Result

	OS-CON	Aluminum electrolytic capacitor
25°C	31mVp-p	42mVp-p
0 °C	30mVp-p	78mVp-p
-20°C	30mVp-p	167mVp-p

(3) Ripple voltage waveform after endurance test (125°C × 10V applied × 1000h)

**OS-CON (10SVPD56M)**  
56 μF/10V

**Aluminum electrolytic capacitor**  
330 μF/10V

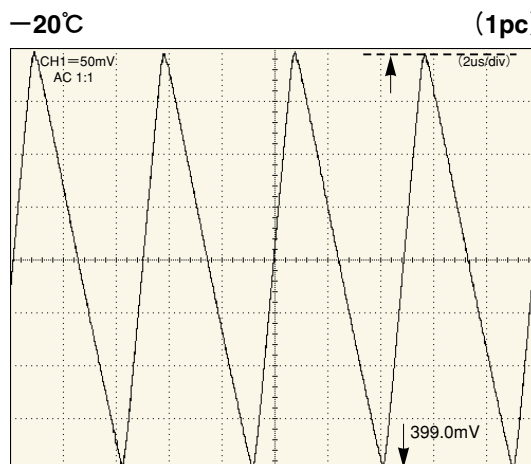
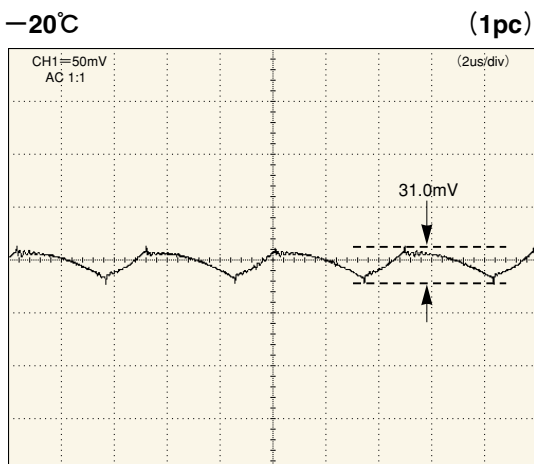
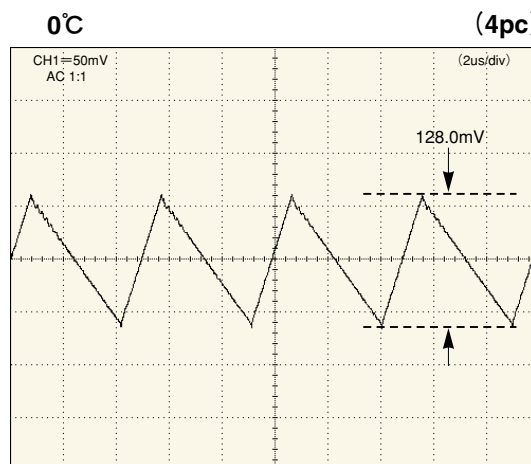
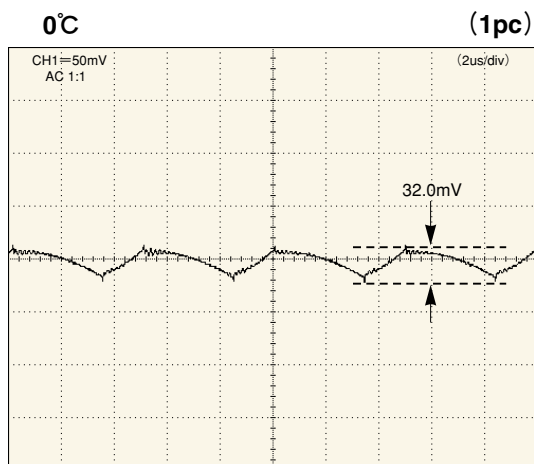
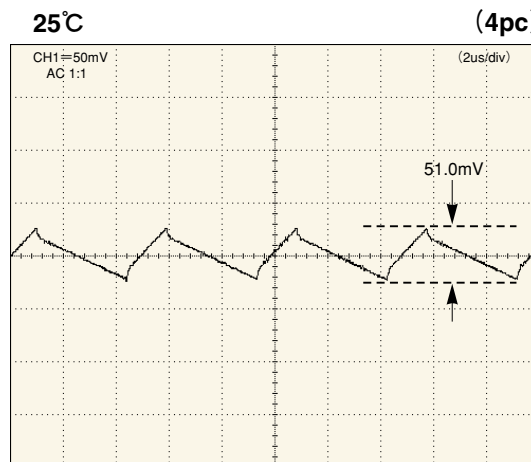
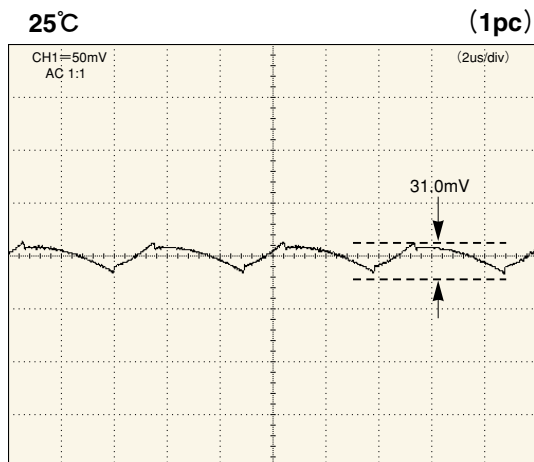

(4) Result

	OS-CON	Aluminum electrolytic capacitor
25°C	31mVp-p	51mVp-p
0°C	32mVp-p	128mVp-p
-20°C	31mVp-p	399mVp-p

## 2. OS-CON high speed back-up performance (Back-up capacitor for dynamic load)

IC, especially MPU that are lately used in electronic devices operate at very high processing speed. PCB s are able to be more densely populated by lowering voltage and getting narrow pattern space. Involved in changing to lower voltage, load current is increasing with a development of new MPU. A sudden change of load current with larger dynamic load at high speed causes the voltage fluctuation of power supply line, and it makes MPU work wrong.

Capacitors with low ESR and large capacitance are necessary for high-speed load current transients. The OS-CON can provide the largest capacitance among low ESR capacitors, and in this regard, the OS-CON is a suitable back-up capacitor.

Let us explain the excellent back-up performance of OS-CON compared to that of other electrolytic capacitors.

### 2-1. Test condition

#### Test circuit

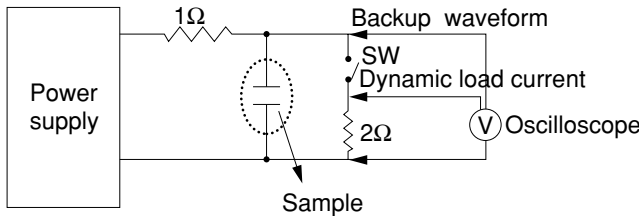

#### Load condition

Item	Condition
Load width	5μs
Cycle	12.5μs
Rising time	20ns
Dynamic load current	2A
Voltage	4V
Power supply impedance	1Ω

#### (a) Switching wave form

##### Whole wave form

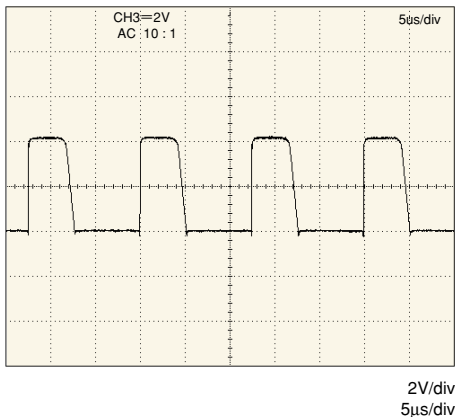

##### Rising wave form

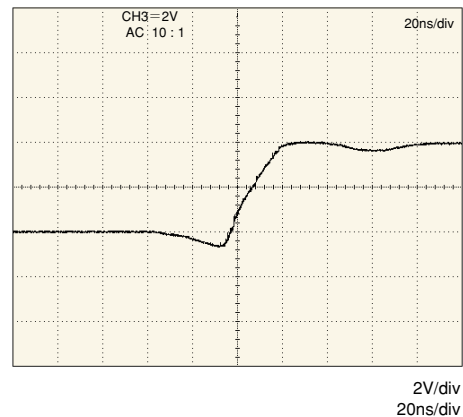

Suitable back-up capacitor for an AC volt tolerance can be estimated from the following equation:

$$\Delta V = \frac{\Delta I \times \Delta t}{C} \times \frac{T - \Delta t}{T} + \Delta I \times ESR$$

$\Delta V$  : AC Volt tolerance (V)

$C$  : Capacitance (F)

$\Delta I$  : Dynamic load current (A)

ESR : ESR ( $\Omega$ )

$\Delta t$  : Load width (s)

$T$  : Cycle (s)

## 2-2. Result

### (a) Comparison between OS-CON and other capacitors with same capacitance

Compared with same capacitance, OS-CON voltage drop of supply line is 104mV, but low-impedance Aluminum electrolytic capacitor indicates 548mV (5.3times of OS-CON), and low ESR Tantalum electrolytic capacitor indicates 212mV (2times of OS-CON).

#### OS-CON

10SP100M, ESR : 21m $\Omega$

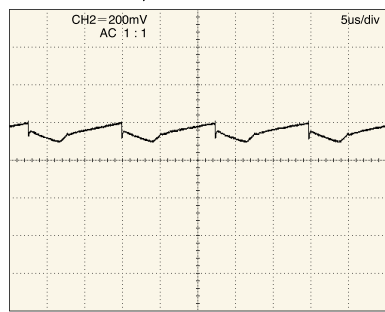

$\Delta V=104\text{mV}$

200mV/div  
5 $\mu$ s/div

#### Low Z Aluminum capacitor

10V100 $\mu$ F, ESR : 245m $\Omega$

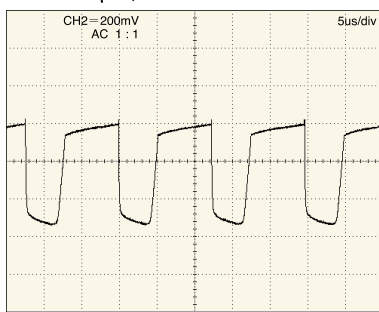

$\Delta V=548\text{mV}$

200mV/div  
5 $\mu$ s/div

#### Low ESR Tantalum capacitor

10V100 $\mu$ F, ESR : 85m $\Omega$

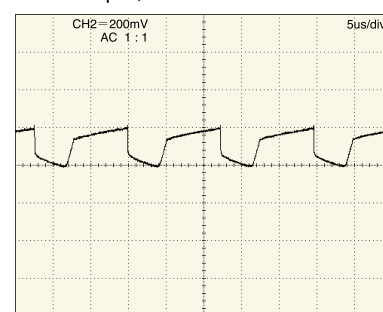

$\Delta V=212\text{mV}$

200mV/div  
5 $\mu$ s/div

### (b) Examination of same level variable load

To obtain similar level of voltage drop to 10SP100M, Low Z Aluminum electrolytic capacitor needs 1,500 $\mu$ F or more. Low ESR Tantalum electrolytic capacitor needs 220 $\mu$ F X 2pcs or more.

#### OS-CON

10SP100M

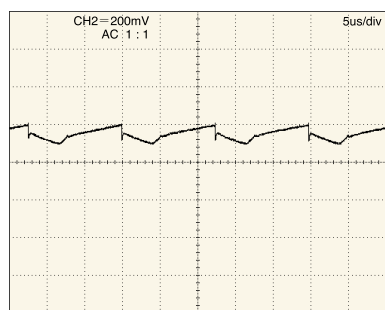

$\Delta V=104\text{mV}$

200mV/div  
5 $\mu$ s/div

#### Low Z Aluminum capacitor

10V1,500 $\mu$ F

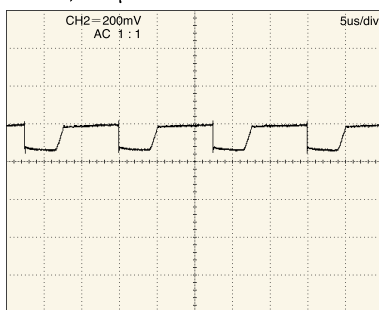

$\Delta V=128\text{mV}$

200mV/div  
5 $\mu$ s/div

#### Low ESR Tantalum capacitor

10V220 $\mu$ F X 2

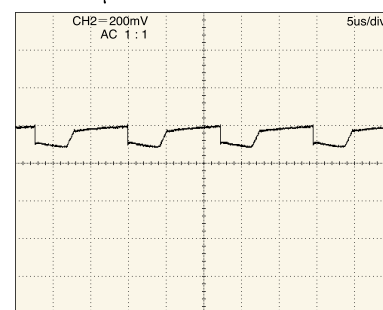

$\Delta V=116\text{mV}$

200mV/div  
5 $\mu$ s/div

### (c) Comparison with lower temperature (-20°C) of (b)

Compared them under the lower temperature, OS-CON is able to keep stable, while the low Z aluminum capacitor has 3.2 times larger drop of the voltage and the low ESR tantalum capacitor has 1.2 times larger drop of the voltage.

#### OS-CON

10SP100M

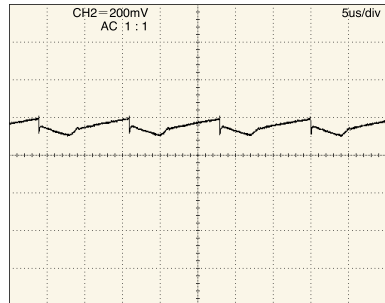

$\Delta V=104\text{mV}$

200mV/div  
5 $\mu$ s/div

#### Low Z Aluminum capacitor

10V1,500 $\mu$ F

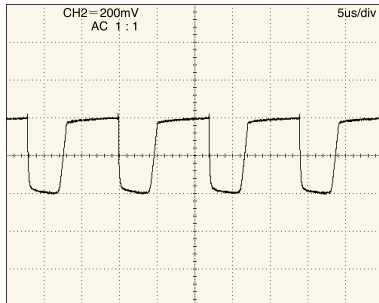

$\Delta V=404\text{mV}$

200mV/div  
5 $\mu$ s/div

#### Low ESR Tantalum capacitor

10V220 $\mu$ F X 2

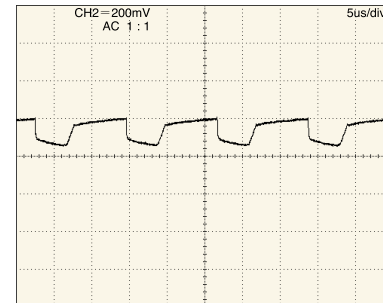

$\Delta V=144\text{mV}$

200mV/div  
5 $\mu$ s/div

### 3. Application to low-pass filter circuits

As a means of removing noise from power supply lines, a low-pass filter such as shown below may be used. In recent years, switching power supplies have become a main power source, that are compact and highly efficient, but they make a large noise source. Also, digital circuits make noise easily, and in most of the devices with mixed noise-sensitive analog circuits, entry of high-frequency noise into the analog circuits is prevented by connecting these low-pass filters to the power supply lines of the analog circuits.

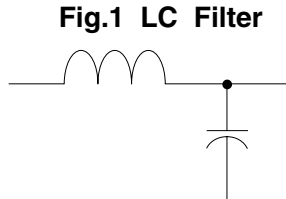

Fig.1 LC Filter

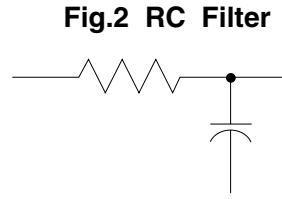
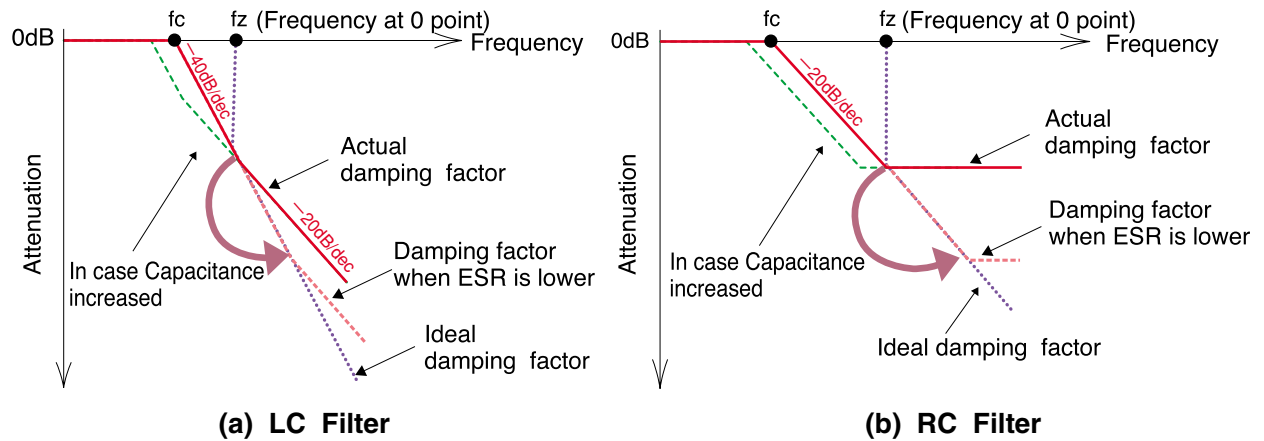

Fig.2 RC Filter

- (a) The damping effect of the filter gets closer to an ideal damping rate as capacitor has lower ESR.
- (b) Capacitance and ESR have 0 point frequency ( $f_z$ ), when the frequency is higher than 0 point frequency, +20dB/dec cancel the damping effect.
- (c) LC filter : -40dB/dec is to be -20dB/dec  
RC filter : -20dB/dec is to be 0 (non-damping effect)
- (d) Even if capacitance is increased, there has no effect of noise cutting, it is influenced by the 0 point frequency.

OS-CON is most effective in low-pass filter because of low ESR.

Fig.3 Actual damping factor



Compare the actual damping factor of the following OS-CON with an aluminum electrolyte capacitor on the next page

The capacitors used for comparison are as follows

OS-CON (16SA33M)  
16V/33uF, ESR=37mΩ (The actual measurement)

Aluminum electrolytic capacitor  
10V/33uF, ESR=1410mΩ (The actual measurement)

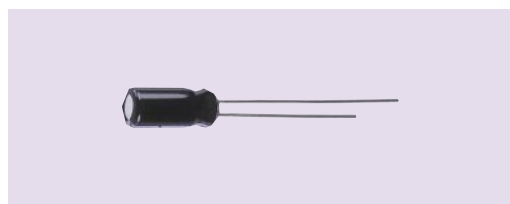
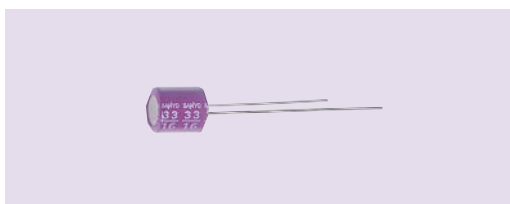

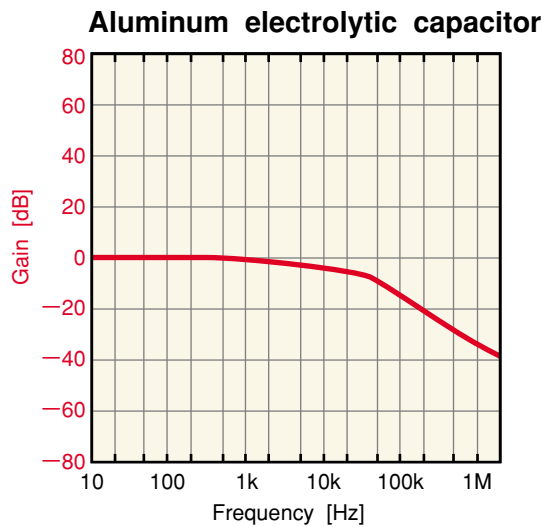
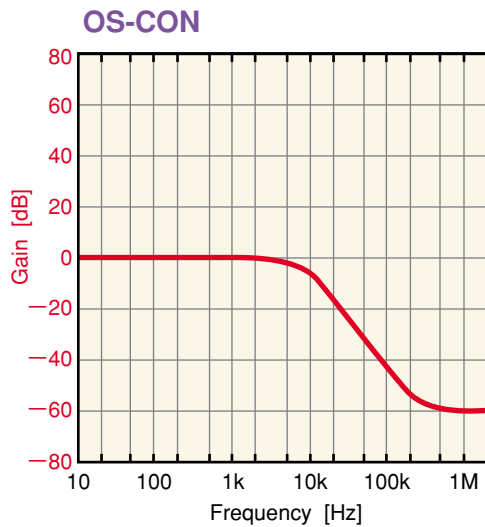
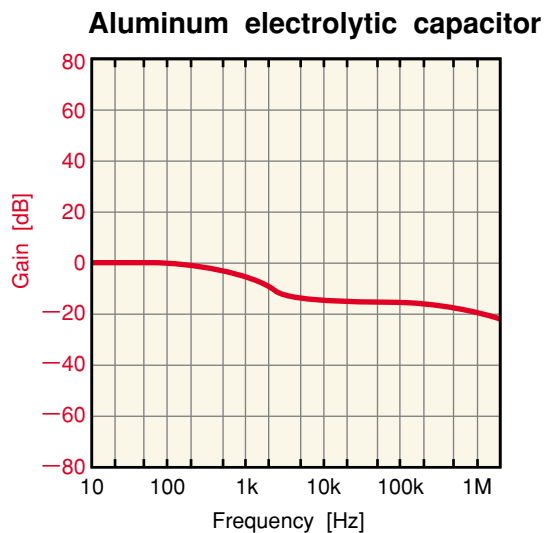
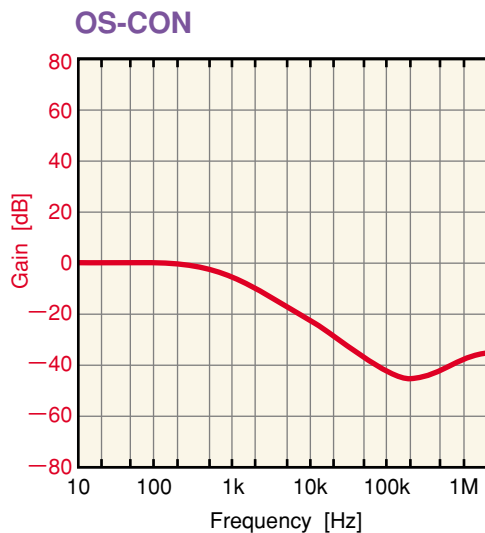
**3-1. LC Filter (L=10uH)****3-2. RC Filter (R=5.6%)**

**OS-CON** shows a damping effect in higher frequency regions comparing with an aluminum electrolytic capacitor.

These measurements were made at room temperature. The difference in damping effect will be larger when the temperature is under 0°C, because ESR of an aluminum electrolytic capacitor will extremely increase. Oppositely **OS-CON** has little increase that does not affect the damping effect of the filter.

## 4. Application of switching power supply for smoothing capacitor

For restraining output ripple current, the output smoothing capacitor of the switching power supply is need to use low ESR capacitor. However the lower ESR capacitor makes the phenomenon sometimes occurs, which is called the abnormal oscillation of output voltage.

The abnormal oscillation of output voltage varies depending on the regulator method or the topology such as buck type, boost type, etc. We explain the mechanism and the treatment method of output voltage oscillation with the sample of the Buck style switching regulator under the voltage control mode.

### 4-1. Abnormal oscillation of output voltage

The switching power supply usually has the negative feed-back circuit to stabilize output voltage.

The difference between output voltage and standard voltage  $V_{ref}$  are amplified with the error amplifier and convert to the digital signal with the PWM comparator and flip on and flip off switch Q1.

Input voltage  $V_{in}$  becomes a square wave form by Q1, and you obtain DC output voltage  $V_{out}$  by make it smooth with coil L and capacitor  $C_{out}$ . L and also  $C_{out}$  assumed that they form the second low pass filters.

The frequency characteristics of the output LC filter is expressed with the Bode diagram like Figure 2.

The phase is delayed 180 degrees originally, because the error amplifier is a negative feedback circuit. Therefore, the phase delay of the output LC filter and the error amplifier occur at the same time, and when 360 degrees delay occur, the output voltage oscillates.

Fig.1 Control block of switching power supply

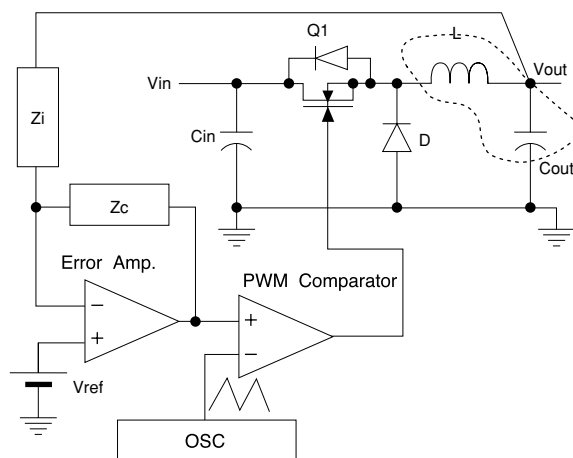

The damping rate of the LC filter is  $-40\text{dB/dec}$  and the cut-off frequency becomes  $\frac{1}{2\pi\sqrt{LC}}$ , and become Gain and Phase like the dotted line of Figure 2.

With an ideal filter the output voltage oscillates because it is delayed 180 degrees. But more than some frequency that is called zero frequency, damping rate of Gain becomes  $-40\text{dB/dec}$  to  $-20\text{dB/dec}$ . Furthermore the Phase returns to delay 90 degrees from delay 180 degrees. This is because the first order Phase lead network is formed by the capacitance value and ESR of  $C_{out}$ . Because, after the zero point frequency  $\frac{1}{2\pi C_{out} ESR}$ , the Gain damping rate goes on the Phase of  $+20\text{dB}$ ,  $+90$  degrees. However, when the low

ESR capacitor is used, it works as a LC filter up to high frequency band, and the phase delay to nearly 180 degrees and it becomes easy to oscillate.

30 degrees to 40 degrees or more of Phase margin is thought as a necessity to inhibit the oscillation of output voltage with a general negative feed-back circuit. The Phase margin is numerical value how much the minimum value of the Phase is distant from-180 degrees. The smaller the Phase margin gets, the higher the possibility to oscillate by the characteristic dispersion and temperature change of the component will be.

Fig.2 Frequency characteristic of LC filter

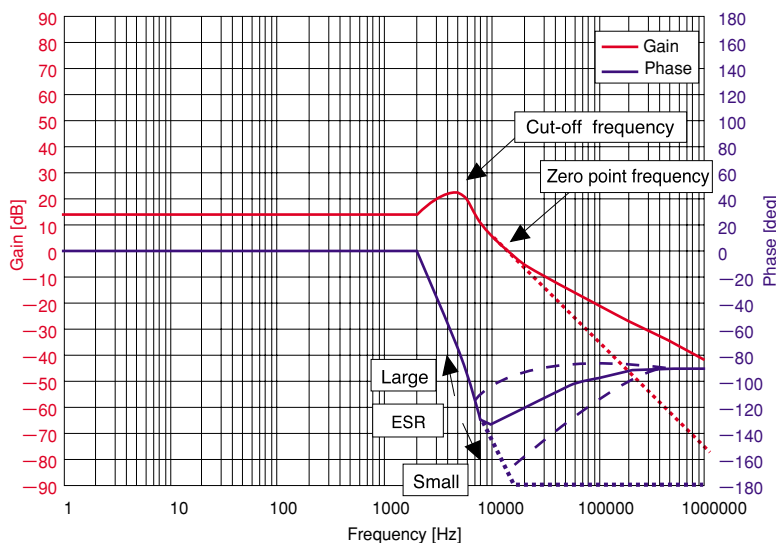

## 4-2. Inhibition method of oscillation

By doing Phase compensation with the feed-back circuit of the error amplifier the oscillation of output voltage can be inhibited.

There are various kinds in Phase compensation. It is most effective to use the Phase compensation circuit like the following in the switch power supply of the voltage control mode.

Figure 3 : ② & ④ form first order Phase lead network. ① & ③ form first order Phase lag network.

By adjusting these values, it does the Phase compensation by which Phase will occur and improve Phase delay of the whole negative feed-back circuit by the frequency characteristic of output LC filter at the frequency band which the Phase indicates the lowest.

Fig.3 Phase compensation network of Voltage Control Mode

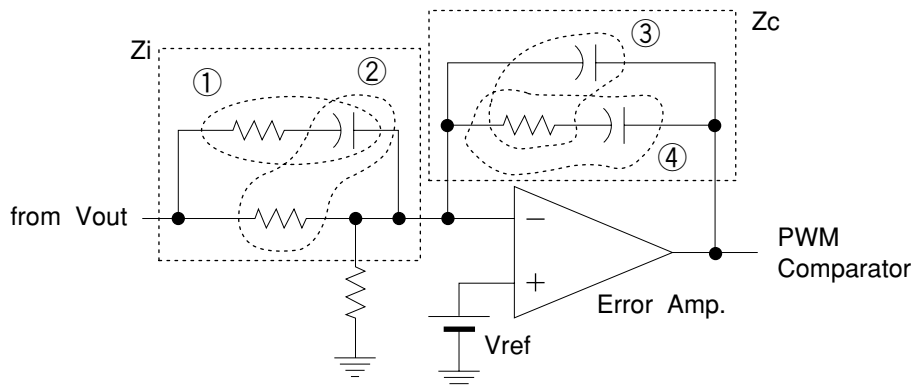
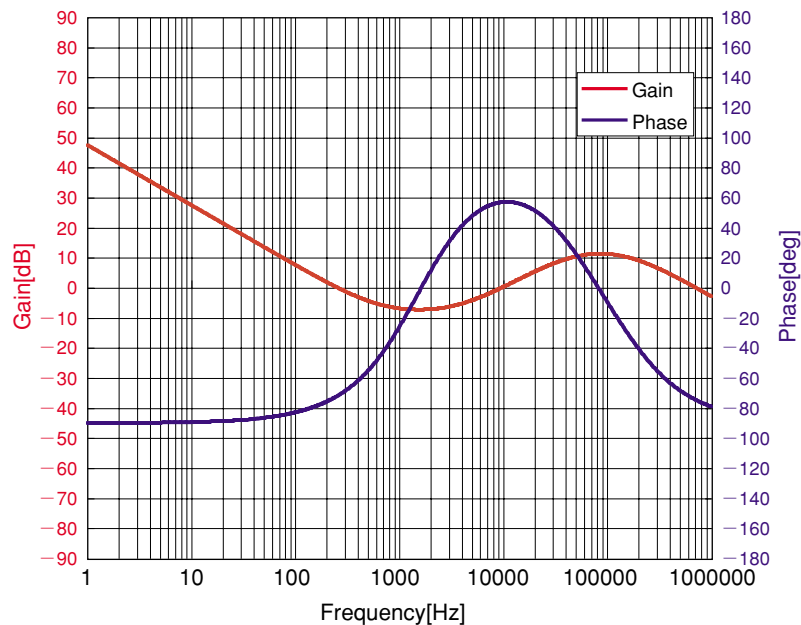

Figure 4 : Example. As the Phase of the output LC filter of Figure 2 becomes a lowest point at around 10kHz, it has about 30 degrees of Phase lead around that frequency. Because of this, it can secure the Phase margin of 30 degrees even if the Phase delay of LC filter becomes 180 degree nearly, the oscillation of output voltage can inhibited.

Related in detail, please inquire it to us.

Fig.4 Frequency characteristic of Phase Compensation Network



### 4-3. Concrete design examples of prevention oscillation

Fig.5 Step-down DC-DC converter design example

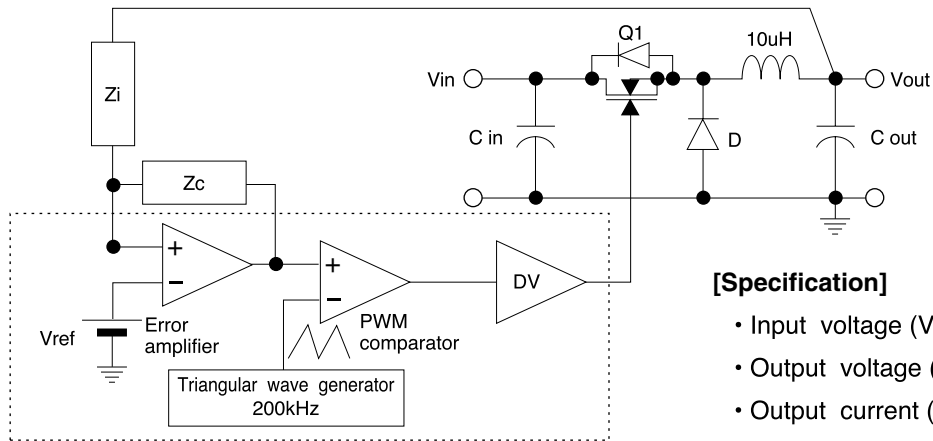

The ESR of the output capacitor necessary to make an output ripple voltage of 20mVp-p can be obtained as follows:

$$ESR < V_{ripple} / ((V_{in} - V_{out}) / L * V_{out} / V_{in} / f_{osc}) = 35.7m\Omega$$

Consequently, the following capacitors have been selected.

#### (a) OS-CON

6SVP100M 1-parallel  $\phi 6.3 \times L6mm$  ESR = 32m $\Omega$  ※ESR is an actual measurement.

#### (b) Aluminum electrolytic capacitor

6V/680uF 3-parallel  $\phi 10 \times L8mm$  ESR = 128m $\Omega/p$ . Total ESR = 43m $\Omega$

### Photograph 1: Measuring evaluation board using the above capacitors

We can downsize by using the OS-CON compared with aluminum electrolytic capacitors if the most favorable phase compensating circuit is provided as follows.

Photo 1 Evaluated circuit boards

#### OS-CON

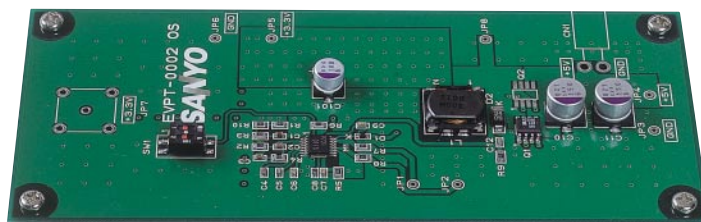

#### Aluminum electrolytic capacitor

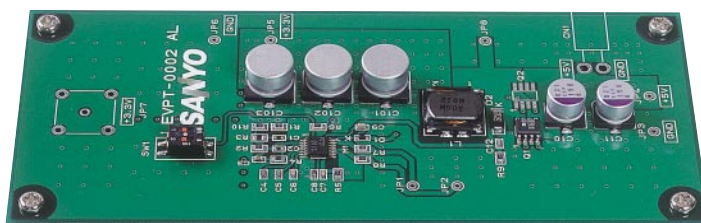

### 4-4. Examples of design with aluminum electrolytic capacitors

When the aluminum electrolytic capacitors are used, the frequency characteristics of the output LC filter are as shown in Fig.6, and there is a sufficient phase margin to such an extent that there is no need to make phase compensation. Therefore, the phase compensating circuit in Fig.7 is sufficient.

Fig.6 Frequency characteristics of the LC filter with the AL-E

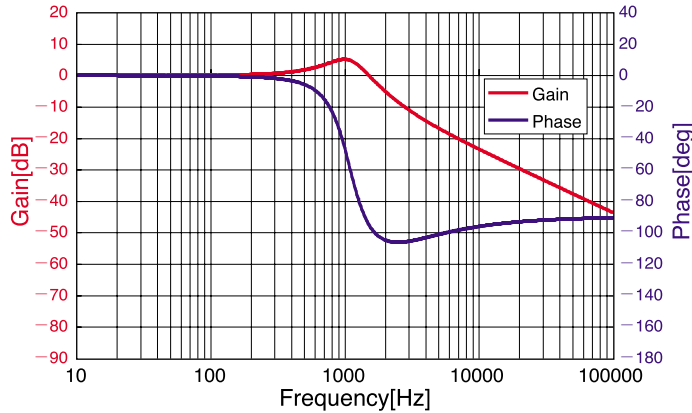
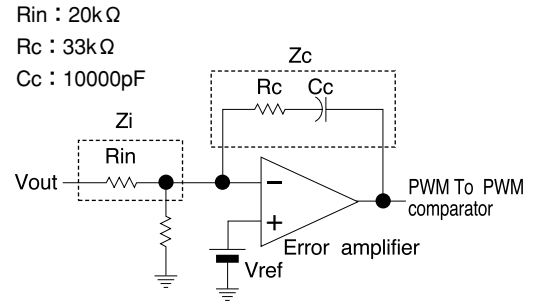

Fig.7 Phase compensating circuit with the AL-E



With the phase compensation network is Fig. 7 (properly speaking, phase compensation is not made), the total frequency characteristics are as shown in Fig. 8, and there is a sufficient phase margin.

Fig8 Total frequency characteristics with the AL-E

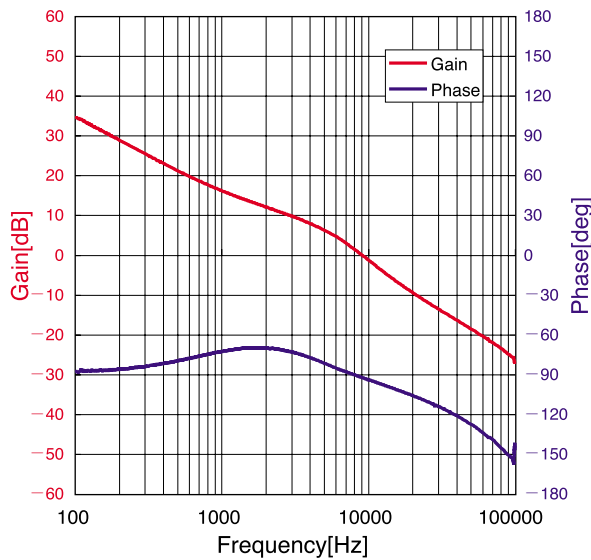
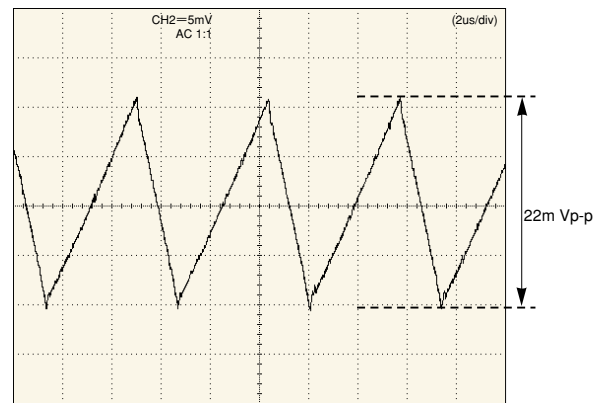

Fig.9 Output ripple voltage waveform with the AL-E



### 4-5. Examples of design with the OS-CON

When the aluminum electrolytic capacitors used in power supply circuits are replaced with the OS-CON without changing the phase compensation network, the output voltage oscillates. (Fig.10)

As a reason, we can say that the phase margin is lost because the phase compensation network is not changed despite the fact that the frequency characteristics of the output LC filter change as shown in Fig.6, where the aluminum electrolytic capacitors are used, to Fig.11, where they are replaced with the low ESR OS-CON.

Fig.10 Oscillating output voltage waveform

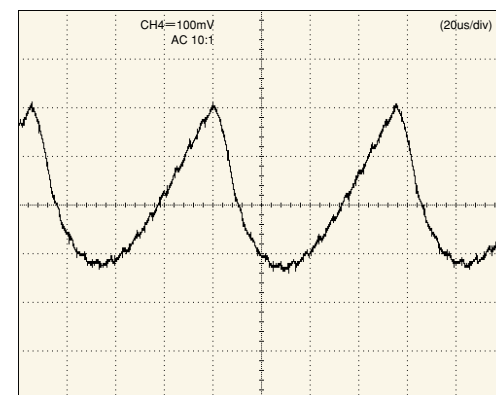

When the LC filter has little phase margin as shown in Fig.11, appropriate phase compensation can be made by using such a phase compensation network as shown in Fig.12. This is to cancel the deepened phase lag by forming phase leads at Zi and Zc in Fig.12.

**Fig.11 Frequency characteristics of the LC filter with the OS-CON**

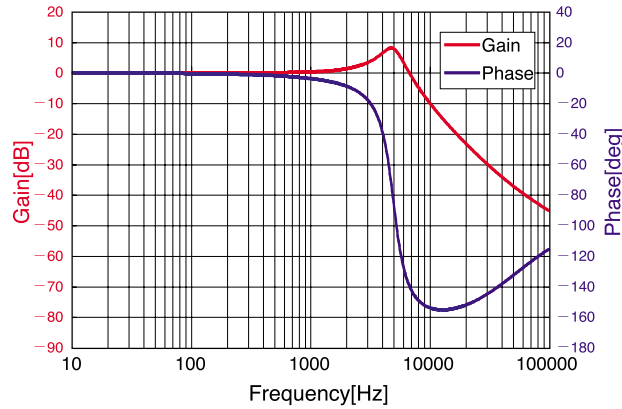

**Fig.12 Phase compensating circuit with the OS-CON**

Rin1 : 20kΩ    Cin : 4700pF    Cc1 : 330pF  
Rin2 : 680Ω    Rc : 3.3kΩ    Cc2 : 33000pF

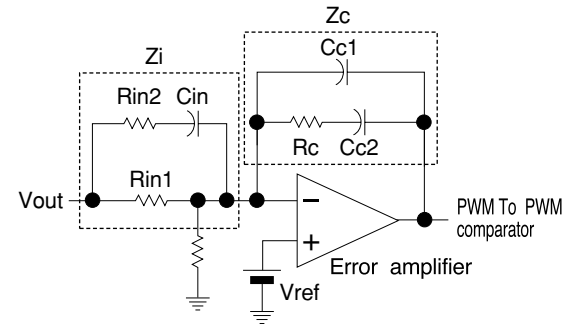

Because of this, the total frequency characteristics are as shown in Fig.13; the phase margin is sufficient; and the output ripple voltage waveform (Fig.14) is almost the same as is the case with the aluminum electrolytic capacitors.

**Fig.13 Total frequency characteristics with the OS-CON**

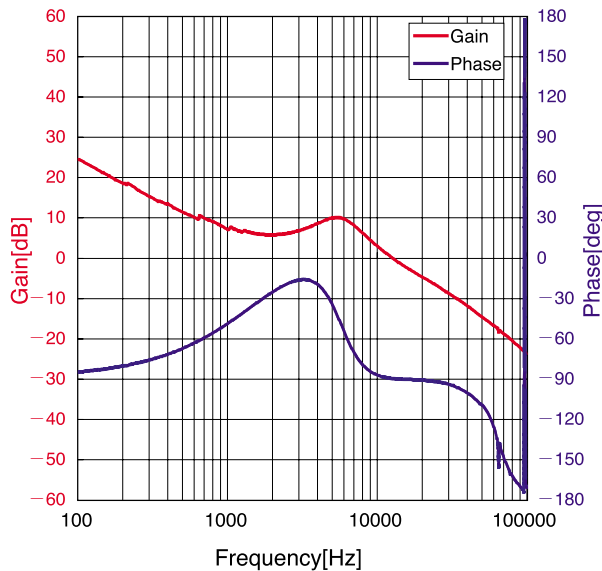

**Fig.14 Output ripple voltage waveform with the OS-CON**

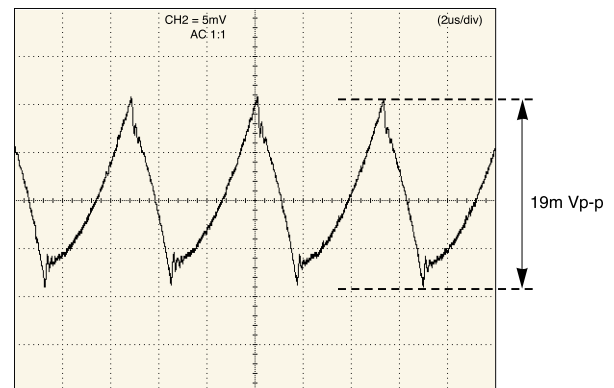

## 5. Influence of output ripples from switching power supply on actual images

Comparison of the output ripple current among **OS-CON**, aluminum electrolytic capacitors and tantalum capacitors on P.72 to P.74. The result showed that the **OS-CON** provided an excellent filter effect, superior to those of other capacitors. This section discusses the influence of such ripples on images. You may understand how digital noise affects analog signals.

### (a) Influence to images by a digital camera

**OS-CON** and low impedance aluminum electrolytic capacitors are connected respectively as output filter in DC-DC converter of a digital camera, and we compare the influences on actual images changing temperature.

#### Parts mounting circuit



**OS-CON** is used  
10V/47  $\mu$  FX2P  
size:  $\phi$  6.3×L5.0

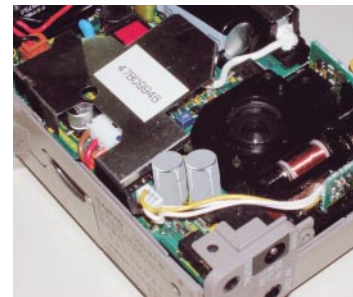

Al-E is used  
10V/330  $\mu$  FX2P  
size:  $\phi$  6.3×L11.0

#### OS-CON ; SL series

Photo 1  
at 25°C



Photo 3  
at 0°C



Photo 5  
at -20°C



#### Low impedance Aluminum electrolytic capacitor

Photo 2  
at 25°C



Photo 4  
at 0°C



Photo 6  
at -20°C

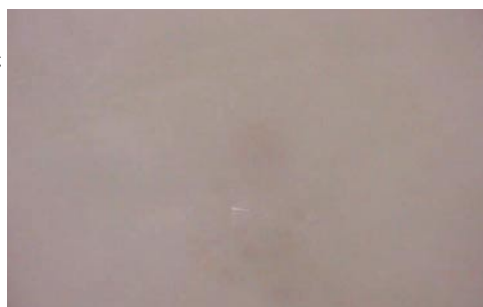

### (b) Result

- (1) Images when use **OS-CON** : There were quite normal when the temperature is from 25°C to -20°C.
- (2) Images when use **low impedance aluminum electrolytic capacitors**: Images started to become white like misting around 0°C as a whole, and images hardly appeared at all at -20°C.